

FY2024-2025  
Joint Research Reports ( International Collaboration )  
2024-2025年度  
共同利用・共同研究報告書( 国際共同研究 )

Joint Usage / Joint Research Committee  
Institute of Materials and Systems for Sustainability, Nagoya University  
名古屋大学未来材料・システム研究所  
共同利用・共同研究委員会

FY2024-2025 Joint Research Reports Contents ( International Collaboration )

2024-2025年度 報告書目次 ( 国際共同研究 )

\*Affiliation displayed are current as of March 2026.

\*所属は2026年3月現在

Reference No. 整理番号	Principal investigator 研究代表者	Affiliation 所属機関	Project title 研究課題名	Page 頁
1 2024-2-001	Roy Byung Kyu Chung	Kyungpook National University	Development of High-Quality $\kappa$ -Ga <sub>2</sub> O <sub>3</sub> Crystal Growth for Realizing Low Power Consumption High-Frequency Devices 低消費電力高周波デバイスを実現する高品質 $\kappa$ -Ga <sub>2</sub> O <sub>3</sub> の結晶成長	1
2 2024-2-003	Akitaka Ariga 有賀昭貴	University of Bern ベルン大学	Digital Archives for Nuclear Emulsion Readout 原子核乾板データアーカイブス	3
3 2024-2-006	Nobusuke Kobayashi 小林信介	Gifu University 岐阜大学	Development of Catalyst Filled Type Fluidized Bed Plasma Reactor for Direct Methanol Production from CO <sub>2</sub>	5
4 2024-2-008	Jiangbo Wang	Dalian University of Technology	Pricing Strategy Optimization of Demand-Responsive Commuter Buses Considering Passenger Loyalty Decay Characteristics	7
5 2025-2-001	Shinichiro Sato 佐藤真一郎	National Institutes for Quantum Science and Technology 量子科学技術研究開発機構	Lanthanoid Ion Implanted GaN Quantum Sensors Fabricated by Ultra High Pressure Annealing 超高圧熱処理法を活用したランタノイドイオン注入GaN量子センサーの開発	9
6 2025-2-007	Teppei Katori 香取哲平	King's College London キングス・カレッジ・ロンドン	Neutron background measurements using emulsion detector at ISIS neutron source	11
7 2025-2-009	Sunita Srivastava	Indian Institute of Technology Bombay	Large scale ordered assembly of functional nanomaterials for energy conversion and flexible energy storage devices.	13
8 2025-2-011	HO, Chinh Quoc	University of Sydney	Mobility as a Service for rural and regional areas: how to go from a blueprint to in-field trials and commercial offers	15

## 低消費電力高周波デバイスを実現する高品質 $\kappa$ -Ga<sub>2</sub>O<sub>3</sub> の結晶成長

### Development of High-Quality $\kappa$ -Ga<sub>2</sub>O<sub>3</sub> Crystal Growth for Realizing Low Power Consumption High-Frequency Devices

Roy Byung Kyu Chung, Assistant professor, Electronic Materials Science and Engineering Department, Kyungpook National University

原田俊太、名古屋大学、未来材料・システム研究所 未来エレクトロニクス集積研究センター 准教授

本共同利用・共同研究課題の研究目的につき、記述下さい。(11pt 明朝体)

## 2. 研究内容と成果

本研究では、スズ (Sn) 添加による  $\kappa$ -Ga<sub>2</sub>O<sub>3</sub> の高品質結晶成長を実現し、低消費電力高周波デバイスへの応用を目指した。特に、結晶成長時に発生する回転ドメインの形成が結晶品質の低下を引き起こすことから、その評価手法の確立と抑制メカニズムの解明に重点を置いた。

2024 年度は、回転ドメインのサイズを定量的に評価するための観察手法を確立することを目的に、断面観察と平面観察の比較検討を行った。その結果、平面観察が回転ドメインの分布やサイズを詳細に捉えられることが分かった。これに基づき、透過電子顕微鏡 (TEM) および走査透過電子顕微鏡 (STEM) を用いた高分解能解析を実施し、結晶構造の精密評価を進めた。特に、4 次元走査透過電子顕微鏡法 (4D-STEM) を活用することで、試料上を二次元的に走査する電子プローブの各位置で二次元の回折パターンを取得し、四次元のデータセットを生成することによって、回転ドメインの形成状態を可視化し、その構造を詳細に同定することに成功した。

また、スズ添加による回転ドメイン抑制のメカニズムを明らかにするため、成長界面の原子配列や結晶構造を詳細に解析した。その結果、スズの添加が界面エネルギーを安定化させ、ドメイン形成を抑制する効果があることが示唆された。さらに、X 線回折 (XRD) 測定を併用することで、回転ドメインの発生頻度や結晶の配向性への影響を定量的に評価し、スズ添加による構造安定化のメカニズムをより精密に理解することができた。

加えて、結晶成長プロセスの最適化に向けた基礎検討も行い、スズの添加量や成長温度が回転ドメインの抑制に与える影響について解析した。これにより、スズの適切な添加条件を特定するための指標を得ることができた。さらに、ミスチ化学気相堆積 (CVD) 法を用いた成長プロセスの安定性を評価し、再現性の高い成長条件の確立に向けたデータを蓄積した。

2025 年度には、これらの知見を基に結晶成長プロセスを改良し、回転ドメインのさらなる抑制を図るとともに、高性能デバイスの試作と評価を進める予定である。本年度の研究により、高品質  $\kappa$ -Ga<sub>2</sub>O<sub>3</sub> の成長技術を発展させるための評価基盤を確立し、次年度のデバイス応用研究への展開が期待される。

### 【研究成果の公表状況】

<国際・国内会議> (11pt 明朝体, Times)

Chan Woong Kim, Ha Young Kang, Yoonho Choi, Roy Byung Kyu Chung, Band Offsets and Interface Engineering of  $\kappa$ -Ga<sub>2</sub>O<sub>3</sub>/ $\alpha$ -Ga<sub>2</sub>O<sub>3</sub> Hetero-Interface, 第11回アジア太平洋ワイドギャップ半導体ワークショップ (APWS2024), 韓国・釜山, 2024年10月13日~17日.

Ha Young Kang, Chan Woong Kim, Yoonho Choi, Minseok Choi, Roy Byung Kyu Chung, Impact of Fluorine Dopant on the Growth and Phase Stability of  $\kappa$ -Ga<sub>2</sub>O<sub>3</sub>, 第11回アジア太平洋ワイドギャップ半導体ワークショップ (APWS2024), 韓国・釜山, 2024年10月13日~17日

## 和原子核乾板データアーカイブス Digital Archives for Nuclear Emulsion Readout

研究代表者 **Akitaka Ariga** ・ University of Bern, Albert Einstein Center for Fundamental Physics, Laboratory for High Energy Physics ・ Assistant Professor

研究分担者 **Michele Weber** ・ University of Bern, Albert Einstein Center for Fundamental Physics, Laboratory for High Energy Physics ・ Director, Professor

研究分担者 **六條 宏紀** ・ 名古屋大学未来材料システム研究所高度計測技術実践センター ・ 素粒子計測部 助教

研究所担当教員 **佐藤 修** ・ 名古屋大学未来材料システム研究所 高度計測技術実践センター ・ 素粒子計測部 特任准教授

### 1. 研究目的

原子核乾板はデータ取得時に電力を要さない素粒子や宇宙線の検出器であり、同時に記録媒体でもある。ベルン大学は過去 20 年の間に原子核乾板を用いたさまざまな実験を主導し、素粒子実験 (OPERA 実験等) だけでなく反物質実験 (AEgIS 実験) やスイス氷河のミュオンラジオグラフィ (Eiger-mu 実験) など、多種の貴重な試料を有している。しかしながら、当時の読み取り装置の能力の限界からこれまではその一部だけしか分析の対象となつてこなかった。例えば OPERA 実験はヨーロッパで行われた大規模な国際共同ニュートリノ振動実験であり、2001 年から始まり 2015 年までに全体の 50 分の 1 の原子核乾板を解析し、ニュートリノ振動の証拠を報告して終了した。本研究ではこれらの試料を名古屋大学の最新型の読み取り装置 HTS・HTS2 を用いて読み出し、これまで有効活用されてこなかった多くのデータを解析可能とする。そのデータを物理学者だけでなく、一般のアマチュア物理学者が利用できるように共有する。OPERA ニュートリノ実験からはニュートリノ物理だけでなく暗黒物質の探索も可能であり、反物質や氷河ミュオグラフィは一般人の興味を引くテーマである。これらをアーカイブ化することには研究資源の再活用とサイエンスコミュニケーションとして有意義である。本研究は名古屋大学とベルン大学とで共同してプラットフォームを築く。

### 2. 研究内容と成果

2024 年度には、ベルン大学に保管されている原子核乾板試料を名古屋大学へ輸送するための方法について検討を行った。原子核乾板は長期間保存可能な記録媒体である一方、温度変化や振動などの環境条件によっては乳剤の劣化や機械的損傷の可能性がある。そのため、船便輸送に伴う温度変動や振動環境について評価を行うとともに、輸送時の梱包方法や温度管理条件について詳細な検討を実施した。その結果、適切な温度管理と緩衝対策を施すことで、長距離輸送においても乾板試料を安全に輸送できる見通しが得ら

れた。

この検討結果を踏まえ、本番輸送を実施した。輸送は温度約 10℃に管理されたコンテナを用いた船便輸送とし、ベルン大学に保管されていた原子核乾板試料を保管棚ごと輸送する形を採用した。輸送対象となった棚は合計 5 台であり、各棚の総重量は約 630 kg、そのうち約 400 kg が原子核乾板サンプルで構成されている。試料は適切な梱包と固定を行った上でコンテナに積載され、温度管理された状態で輸送された。輸送作業は 2024 年度後半より開始され、2025 年 5 月までにすべての試料の輸送を完了した。

名古屋大学への到着後には、輸送による試料への影響を確認するため、梱包状態および乾板の保存状態の点検を行った。さらに、一部の乾板試料についてテスト的な読み出しを実施し、トラック像の形成状態や読み取り品質の確認を行った。その結果、輸送による顕著な劣化やデータ品質の低下は確認されず、乾板の読み出しが問題なく実施可能であることを確認した。これにより、輸送方法および保存条件が適切であったことが実証された。

一方で、現在名古屋大学に設置されている高速乾板読み取り装置の一部に故障が発生していることに加え、装置の運用が他の優先度の高い研究プロジェクトによって占有されている状況にある。そのため、本研究で計画している大規模な乾板データの体系的読み出しおよびアーカイブ化については、現時点では本格的な実施には至っていない。今後、読み取り装置の復旧および運用体制の調整を進めるとともに、段階的にデータ読み出しとアーカイブ化作業を進めていく予定である。これにより、ベルン大学に蓄積された原子核乾板データを広く活用可能な形で保存・公開する基盤の整備を目指す。また、本研究は過去の大型実験で取得された試料を再解析することで研究資源を有効活用し、新規実験と比較して少ない資源やエネルギーで新たな科学的成果を創出する持続可能な研究の推進にも資する。

#### 【研究成果の公表状況】

<原著論文>なし

<国際・国内会議>なし

<産業財産権> なし

Form 2-2

## Development of Catalyst Filled Type Fluidized Bed Plasma Reactor for Direct Methanol Production from CO<sub>2</sub>

Nobusuke Kobayashi, Faculty of Engineering, Gifu University, Professor

Kenji Kamiya, Faculty of Engineering, Tokyo University of Agriculture and  
Technology, Assistant Professor

Zhang Baiqiang, School of Energy and Power Engineering Zhengzhou University of  
Light Industry, Vice Professor

Naruse Ichiro, Institute of Materials and Systems for Sustainability, Professor

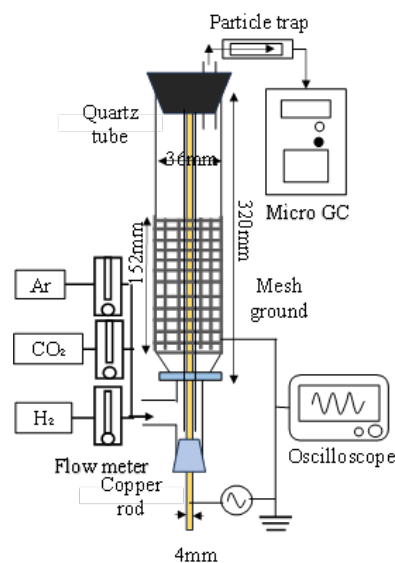
Ueki Yasuaki, Aich Institute of Technology, Faculty of Engineering, Professor

### 1. Research Objectives

In response to global warming concerns, the promotion of regionally distributed renewable energy utilization is being pursued as a future energy system. However, the effective use of renewable energy requires integration with energy storage technologies to ensure stable supply and utilization. To address this challenge, this study focuses on the development of an innovative PCS (Plasma Catalysis System) capable of synthesizing methanol from CO<sub>2</sub> with a simple on-off switching mechanism, allowing for flexible operation in response to fluctuating renewable energy supply and demand. For this purpose, a fluidized-bed PCS system was employed instead of a conventional fixed-bed PCS system. This system enables catalyst fluidization using reaction gases activated by plasma, allowing efficient decomposition of CO<sub>2</sub> and the synthesis of methanol through plasma-driven reactions with CO<sub>2</sub> and H<sub>2</sub>. The study investigates the feasibility and performance of this plasma synthesis process.

### 2. Research Content and Achievements

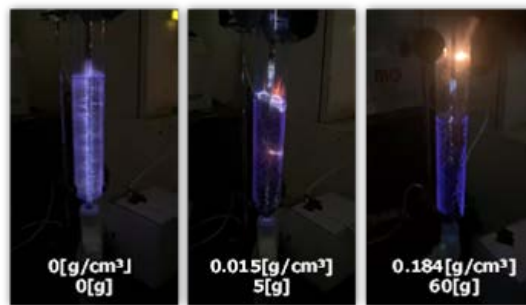
**Figure 1** shows a schematic diagram of the Fluidized-bed PCS. In this system, reaction gases (CO<sub>2</sub> and H<sub>2</sub>) are introduced through a nozzle at the bottom of the reactor, while a voltage is applied between the electrodes to generate plasma. Additionally, argon (Ar) gas, which facilitates plasma generation, was introduced along with the reaction gases. In this experiment, conductive carbon particles with a size range of 150–212 μm, which previously identified in prior studies to significantly enhance CO<sub>2</sub> conversion efficiency, were introduced into the reactor and fluidized between the electrodes. The applied voltage, frequency, and gas flow rate were kept constant at 11.5 kV, 20 kHz, and 7 L/min, respectively. The effect of varying particle loading on gas conversion efficiency and product gas yield was evaluated. During the gas reaction experiments, gas sampling was conducted 10 minutes after plasma initiation, once the plasma and bed temperature had stabilized. The sampled gas was analyzed using gas chromatography. Additionally,



**Fig.1** Schematic diagram of fluidized bed type PCS

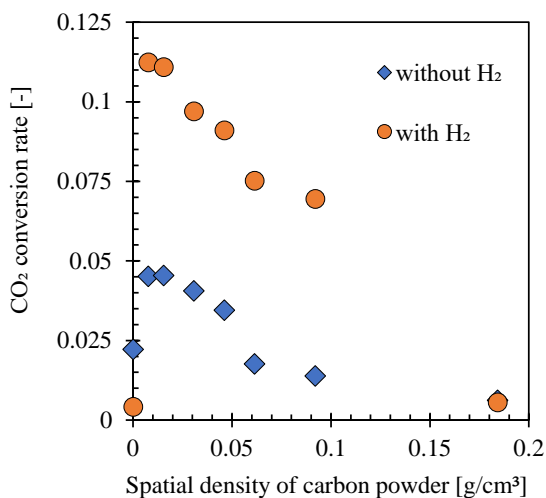
temperature measurements were performed using a thermal camera, current measurements were taken with an oscilloscope, and plasma intensity was monitored using a hyperspectral camera.

**Figure 2** shows the plasma state inside the reactor under different carbon particle loading conditions. The presence of carbon particles significantly affected plasma behavior. When no particles were introduced, a stable glow plasma was observed. However, with the introduction of carbon particles, streamer discharges were generated, and their characteristics varied dynamically depending on the particle behavior within the fluidized bed.

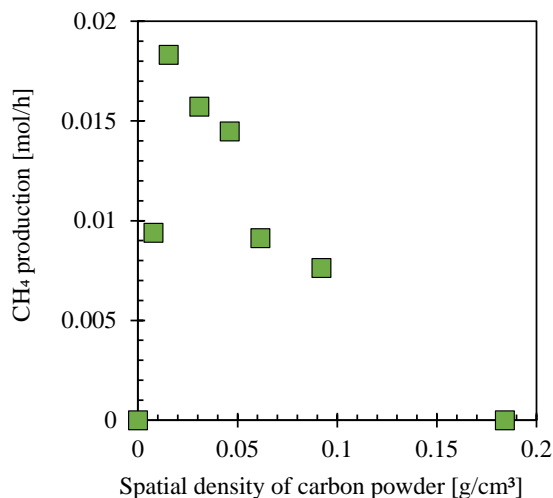


**Fig.2** Plasma in a bed at different amounts of packed particles

**Figures 3 and 4** illustrate the effect of carbon particle loading on CO<sub>2</sub> conversion efficiency and CH<sub>4</sub> production. Due to the high temperature inside the reactor, CH<sub>4</sub> was produced instead of methanol in this reaction. The CO<sub>2</sub> conversion efficiency varied significantly with the carbon particle loading, showing a marked increase compared to the no-loading condition. Furthermore, the addition of H<sub>2</sub> further enhanced the conversion efficiency. As expected, CH<sub>4</sub> was not generated in the absence of H<sub>2</sub>. However, CH<sub>4</sub> production varied considerably with different carbon particle loadings, indicating the existence of an optimal particle loading condition for plasma-induced gas reforming reactions.



**Fig.3** CO<sub>2</sub> conversion



**Fig.4** Production rate of CH<sub>4</sub>

[Status of Research Achievements]

<Original Papers>

- Francis Maina, Kobayashi Nobusuke, Robert Masumbuko, Akira Suami, Baiqiang Zhang, Influence of Particle Distribution on CO<sub>2</sub> Dissociation and Discharge Behaviour in a Fluidized-Bed DBD Reactor, *Plasma Chemistry and Plasma Processing* (Accepted)

<International/National Conferences>

- Francis Irungu Maina, Nobusuke Kobayashi, Akira Suami, Understanding the effects of frequency to discharge power and CO<sub>2</sub> decomposition in a fluidized bed DBD reactor, International Workshop on Environmental Engineering 2025 (IWEE2025) Hokkaido, Japan, July 18-21, 2025

Form 2-2

## Pricing Strategy Optimization of Demand-Responsive Commuter Buses Considering Passenger Loyalty Decay Characteristics

- Jiangbo Wang, Dalian University of Technology, China, School of Economics and Management, Associate Professor
- Kai Liu, Dalian University of Technology, China, School of Economics and Management, Professor
- Yuying Guo, Dalian University of Technology, China, School of Infrastructure Engineering, Master student
- Toshiyuki Yamamoto, Nagoya University, Institute of Materials and Systems for Sustainability, Professor

### 1. Research Objectives

This study aims to conduct an in-depth exploration of the profitability and market impact of introducing long-term tickets in demand responsive transit (DRT) services. It will systematically compare the optimality of three distinct ticketing strategies—single-period tickets, long-term tickets, and a hybrid strategy that combines both—by analyzing key performance indicators across different market scenarios. The research seeks to identify the core exogenous variables that influence DRT operators' pricing decisions, and clarify how these variables quantitatively and qualitatively affect optimal pricing, market share allocation, and overall profit outcomes.

A critical objective is to develop a robust theoretical optimization framework, it will be built on a modified Hotelling model to address the unique characteristics of DRT services, filling the gap in existing literature lacking tailored economic models for ticketing strategy design in DRT systems. Finally, the study intends to translate theoretical findings into guidance for DRT operators, providing concrete recommendations on differentiated ticket design, dynamic pricing adjustments in response to market changes, and strategies, supporting operators in enhancing financial sustainability and passenger satisfaction.

### 2. Research Content and Achievements

- This research focuses on the ticketing strategy of commuter-oriented DRT services, exploring the profitability and market impact of introducing long-term tickets. It first clarifies the characteristics of DRT with ticket prices higher than traditional buses, points out the practical demand for long-term tickets amid repeated booking costs and stable commuting needs.
- The research constructs a theoretical framework rooted in the Hotelling model, as shown in Figure 1. Key factors integrated into the model include passengers' heterogeneous expected subscription durations, influenced by employment stability, commuting regularity, and residential patterns, time discount rates, unit satisfaction deviation costs which is arising from mismatches between preferred and actual ticket validity periods, and linear operational costs. It assumes passengers' preferred subscription durations follow a uniform distribution—

validated by empirical fitting of 21 months of subscription data from a Dalian DRT system—and establishes generalized utility functions, incorporating basic travel utility, ticket price costs, and satisfaction deviation costs, as well as profit functions.

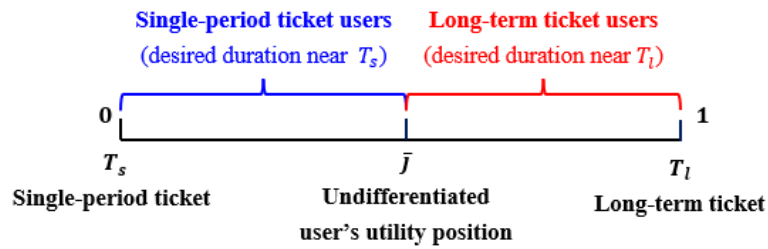


Fig.1 User's subscription duration preferences and ticket choice under the Hotelling model

- Three ticketing strategies are compared: single-period tickets only, long-term tickets only, and a hybrid strategy (combining both). For each strategy, the study derives optimal pricing, market share, and profit under partial and full market coverage scenarios through mathematical modeling and optimization. It further analyzes how exogenous variables (basic travel utility, discount factor, satisfaction deviation cost, operational cost, long-term ticket usage length) affect strategy outcomes, and explores passenger utility distribution differences across strategies.
- Additionally, the research discusses the robustness of findings under alternative distributions and cost structures, and extends the theoretical framework's applicability to traditional public transportation systems, providing theoretical supplements and practical guidance for DRT operators' ticketing decisions.

#### [Status of Research Achievements]

##### <Original Papers>

- Jiangbo Wang, Yuying Guo, Jiyan Wu, Kai Liu\*, Anthony Chen, Toshiyuki Yamamoto, Should Customized Bus Services Offer Long-Term Tickets? An Analysis of Profitability and Market Impact, *Transportation Research Part E: Logistics and Transportation Review*, 205: 104457 (2026-1).

##### <International/National Conferences>

- Jiangbo Wang (Invited Lecture) , Yuying Guo, Jiyan Wu, Kai Liu, Toshiyuki Yamamoto, Analysis of Pricing Strategies and Profit Models for Long-Term Tickets in Customized Bus Services , *International Conference on Materials and Systems for Sustainability 2025*, Nagoya University, December 12-14, 2025.

##### <Projects>

- Optimization of Carbon Emission Management Policy and Low-Carbon Travel Induction Strategies for Demand-Responsive Transportation Systems, NSFC-JSPS Bilateral Workshop Project, 2025.04-2027.12

(Note: Form 2-1 should be one A4-sized page, and Form 2-2 should be two A4-sized pages, including figures and tables.)

## 超高压熱処理法を活用した ランタノイドイオン注入 GaN 量子センサーの開発

Lanthanoid Ion Implanted GaN Quantum Sensors

Fabricated by Ultra High Pressure Annealing

佐藤 真一郎・量子科学技術研究開発機構(QST)・高崎量子技術基盤研究所・グループリーダー

Michal Bockowski・ポーランド科学アカデミー・高圧物理研究所・教授

出来 真斗・名古屋大学・ディープテック・シリアルイノベーションセンター  
イノベーション創出支援部門・准教授

伊藤 慎・名古屋大学大学院 工学研究科 電子工学専攻・博士後期課程 2 年

天野 浩・名古屋大学、未来材料・システム研究所・教授

本田 善央・名古屋大学、未来材料・システム研究所・教授

### 1. 研究目的

パワーエレクトロニクスの高性能化・省エネ化の鍵となる窒化ガリウム(GaN)パワー素子開発を加速させるためのセンシング技術として、GaN にドーパしたプラセオジウム(Pr)の発光特性を利用した量子センシング手法を開発することが本研究の目的である。GaN デバイス内部もしくは極近傍の局所領域に微量の Pr イオンを注入し、超高压熱処理法によりイオン注入損傷の回復と高効率活性化を行うことで、GaN デバイス動作中の Pr イオンの発光を高感度に検出するとともに、デバイス内の電界・電流や温度の変化に伴って生じる発光特性の変化を明らかにする。

### 2. 研究内容と成果

まず、GaN にイオン注入した Pr の電子状態や周辺原子構造について解析するため、SPring-8 BL14B1 にて X 線吸収微細構造(XAFS)測定を行った。試料は以下の手順で作製した。まず、GaN(0001)基板上に成長した n 型 (Si ドープ) GaN エピ層に対し、QST 高崎研のイオン注入装置を用いて、表面から 150 nm の深さにわたり約  $10^{20} \text{ cm}^{-3}$  となるよう Pr イオンを注入した。その後、 $\text{N}_2$  雰囲気中大気圧下  $1200^\circ\text{C}$  で 2 分間 (キャップアニール) もしくは超高压  $\text{N}_2$  雰囲気中(1 GPa)下  $1480^\circ\text{C}$  で 30 分間(UHPA)の熱処理を行った。

図 1 は GaN:Pr の Pr L-III 吸収端 XANES スペクトルであり、 $\text{Pr}^{3+}$  のリファレンスとして  $\text{Pr}_2\text{O}_3$  のスペクトルも示してある。GaN:Pr のピークエネルギーは、熱処理の有無に関係なく  $\text{Pr}_2\text{O}_3$  のピークエネルギーとよく一致し、注入された Pr イオンの価数が +3 であることを示している。キャップアニール後はスペクトル強度の増加とピーク線幅の減少が起こっていることから、GaN 結晶における注入損傷が熱処理によって回復した結果、注入された Pr イオン周辺の局所構造の対称性が改善されたと考えられる。従って、イオン注入後の熱処理による Pr イオンの発光強度の増加は、価数 (+3 価) の安定化では

なく、非発光遷移過程の減少に主に起因するといえる。しかしながら、UHPA 後はピーク強度が再び低下しており、局所構造の乱れが何らかの要因で引き起こされている可能性がある。

次に、XAFS 解析にて得られた知見などをもとに、Pr をイオン注入した GaN エピタキシャル膜に pn 接合ダイオードもしくはショットキー接合ダイオード (SBD) を作製し、デバイス動作中の Pr イオンの発光特性について解析した。pn 接合ダイオードでは、順方向電圧印加時に Pr の電流注入発光を観測することに成功した。SBD では、順方向電圧印加 (通電) 中の内部抵抗に伴う温度上昇を Pr のフォトルミネッセンススペクトルの変化から検出できることを実証した。今後、さらなる解析を進めるとともに、電流注入発光を用いた量子センシング手法の開発に取り組む。

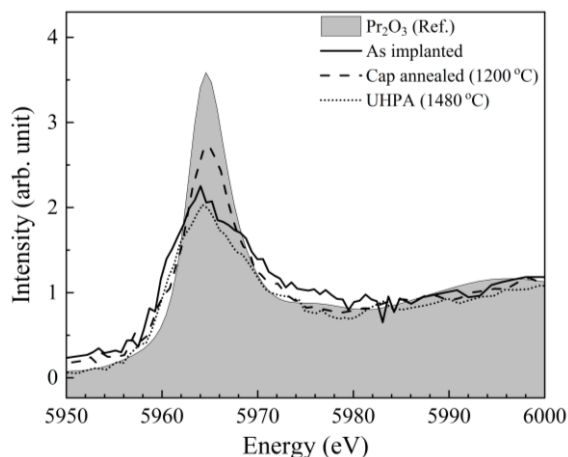


図 1. GaN にイオン注入した Pr の  $L_{III}$ -edge XANES スペクトル。実線：熱処理なし、破線：1200 °C キャップアニール後、点線：1480 °C UHPA 後。参照スペクトルとして  $Pr_2O_3$  を灰色で表示。

### 【研究成果の公表状況】

<原著論文> なし

<国際・国内会議>

- ・ 佐藤 真一郎、横塚 恵莉、圓谷 志郎、長澤 尚胤、齋藤 寛之、辻 卓也、松村 大樹、伊藤 慎、渡邊 浩崇、出来 真斗、新田 州吾、本田 善央、天野 浩、Michal Bockowski、「窒化ガリウムにイオン注入したプラセオジムの電子状態と配位構造」、第 41 回希土類討論会、倉敷、2025 年 5 月 21、22 日
- ・ S. Ito, S.-I. Sato, M. Boćkowski, M. Deki, H. Watanabe, S. Nitta, M. Kushimoto, A. Tanaka, K. Yoshida, H. Minagawa, Y. Honda, and H. Amano, “Room temperature electroluminescence of Pr-implanted GaN p-n junction diode,” 15<sup>th</sup> International Conference on Nitride Semiconductors, Malmö, July 6-11, 2025.
- ・ S.-I. Sato, E. Yokozuka, S. Entani, N. Nagasawa, H. Saitoh, T. Tsuji, D. Matsumura, S. Ito, M. Deki, Y. Honda, H. Amano, S. Nitta, and M. Boćkowski, Coordination Geometry of Praseodymium Ions Implanted in Gallium Nitride and Its Sensing Application, International Conference on Materials and Systems for Sustainability 2025, Nagoya, Dec. 12-14, 2025.
- ・ S. Ito, S.-I. Sato, M. Boćkowski, M. Deki, H. Watanabe, S. Nitta, M. Kushimoto, A. Tanaka, K. Yoshida, H. Minagawa, Y. Honda, and H. Amano, Room temperature electroluminescence of Pr-implanted GaN p-n junction diode, International Conference on Materials and Systems for Sustainability 2025, Nagoya, Dec. 12-14, 2025.

<産業財産権> なし

Form 2-2

## Large scale ordered assembly of functional nanomaterials for energy conversion and flexible energy storage devices.

Sunita Srivastava, Department of Physics, Indian Institute of Technology Bombay,  
Associate Professor

Gayathri Madhavankutty,, Department of Physics, Indian Institute of Technology Bombay,  
PhD student

Chandan Kumar, IMASS, Nagoya University, Researcher

Miho Tagawa, IMASS, Nagoya University, Professor

### 1. Research Objectives

The objective of this project is to establish a transferable strategy for fabricating large-area, ordered and homogeneous nanomaterial assemblies at soft interfaces, and to identify the key physicochemical parameters that govern their structural organization and functionality. In the original concept, nanostructured building blocks were expected to provide advantages such as stress accommodation, shortened transport lengths, and increased interfacial contact area, thereby enabling improved reaction rates and electrochemical performance in next-generation energy systems.

To ensure broad applicability across nanomaterial classes, we focus on bottom-up self-assembly at two-dimensional (2D) interfaces created by Langmuir layers, where interfacial fluidity can facilitate particle rearrangement toward long-range ordering. A central goal is to develop structure–process relationships by systematically controlling interfacial interactions (e.g., ionic strength and pH of the subphase) and quantifying how these controls regulate adsorption, clustering, thickness, and roughness of the assembled films.

Methodologically, we aim to combine in situ Langmuir monolayer measurements with advanced structural characterization, including X-ray reflectivity (XRR) and related interface-sensitive probes, complemented by AFM for morphology, to obtain both in-plane and out-of-plane descriptors of the assembled nanomaterial layers. These objectives provide a robust materials-agnostic foundation for future translation to ordered hybrid architectures and device-oriented assemblies envisioned in the proposal.

### 2. Research Content and Achievements

In this collaborative research, we developed an interface-guided assembly route to create laterally organized nanomaterial films under two-dimensional confinement at the air–water interface. A positively charged DMTAP (1,2-dimyristoyl-3-trimethylammoniumpropane) monolayer was used as a soft template, and the adsorption/organization of dispersed nanomaterials was tuned by controlling the ionic composition of the aqueous subphase (water, saline, and basic).

The interfacial assembly process was quantified in situ using Langmuir compression (P–A) isotherms and mechanical response (elastic modulus), where systematic shifts in lift-off area and increased rigidity provided a direct metric for adsorption and incorporation of nanomaterials at the interface. Experimental control was achieved by preparing three subphases—water (pH ~7), saline (1 mM NaCl; pH ~7), and basic (pH 10)—and by varying nanomaterial

concentration in the subphase.

Film morphology and vertical structure were evaluated *ex situ* after transfer to silicon substrates via the Langmuir–Schaefer method, followed by AFM for in-plane morphology and synchrotron-based X-ray reflectivity (XRR) for out-of-plane thickness, density profiles, and roughness.

A key achievement is the demonstration of robust, general “control knobs” for nanomaterial ordering at charged interfaces. The basic subphase (pH 10) produced the highest adsorption, attributed to stronger electrostatic attraction between negatively charged nanomaterials and the cationic monolayer, while saline showed moderate adsorption and water showed minimal particle–surface interaction. AFM revealed that films on water became relatively uniform with increasing concentration, whereas saline and basic conditions generated increasingly heterogeneous structures at higher concentrations. Mechanistically, heterogeneity arose via cluster-growth dominated processes in saline but via density-driven aggregation under strong adsorption in basic conditions. XRR corroborated these trends, showing increased thickness/roughness under conditions that promote aggregation and confirming a nanomaterial layer thickness on the order of a few nanometers.

These insights are directly relevant to energy conversion and flexible energy storage devices, where performance is often governed by interfacial charge/ion transport and mechanically robust electrode–electrolyte contact. By enabling tunable, large-area nanomaterial films with controlled roughness, thickness, and aggregation state, this interfacial assembly strategy provides a practical pathway to engineer functional layers and hybrid interfaces for future device-oriented architectures.

#### [Status of Research Achievements]

##### <Original Papers>

- [1] Mishra, A.; Roychowdhury, R.; Tagawa, M.; Srivastava, S. Structural morphology of nanoclay films at the air–water interface under varying ionic compositions of the subphase medium. *Nanoscale Advances* **2026**, Advance Article, DOI: 10.1039/D5NA00689A, Publisher: Royal Society of Chemistry.

##### <International/National Conferences>

NA

##### <Industrial Property Rights>

NA

(Note: Form 2-1 should be one A4-sized page, and Form 2-2 should be two A4-sized pages, including figures and tables.)

Form 2-2

## Smart mobility and multi-service platform

- Principal Investigator's Name, Affiliated Institution, Department, Position: HO, Chinh Quoc, University of Sydney, Institute of Transport and Logistics Studies, Associate Professor
- Collaborating Researchers' Names, Affiliated Institutions, Departments, Positions
  - SATO, Hitomi, Nagoya University, Institutes of Innovation for Future Society, Designated Associate Professor
  - YAMAMOTO, Toshiyuki, Nagoya University, Institute of Materials and Systems for Sustainability Division of Systems Research (DS) Professor
  - HUAN, Ning, Institute of Materials and Systems for Sustainability Division of Systems Research, Research Fellow
  - ZHU, Yuanfang, Institute of Materials and Systems for Sustainability Division of Systems Research, Research Fellow

### 1. Research Objectives

Mobility as a Service (MaaS) is a central component of the Smart Mobility Challenge initiative, which aims to address regional challenges and revitalise economies through transport services enabled by digital technologies such as IoT, AI, and automation (METI, 2021). Within this policy context, the primary objective of this collaborative research is to generate robust empirical evidence on how MaaS can be scaled beyond pilot projects to achieve both commercial viability and sustainable transport outcomes. The project adopts an international comparative framework using stated preference (SP) data collected in Australia and Japan to examine the behavioural, institutional, and contextual factors influencing MaaS adoption. Extending MaaS beyond a transport-only concept, the research focuses on multiservice platforms that bundle mobility with non-mobility services such as entertainment, delivery, and digital subscriptions. This approach enables assessment of whether multiservice designs can better align consumer appeal with public policy objectives related to travel demand management and emissions reduction.

### 2. Research Content and Achievements

During the current fiscal year, the research progressed from survey design and pilot analysis to full-scale international data collection, comparative modelling, and dissemination of joint findings. The main research content focused on completing the Japanese stated preference (SP) survey, integrating it with the Australian dataset, and undertaking a rigorous cross-country empirical analysis of multiservice MaaS adoption.

A large-scale SP survey was successfully conducted in Japan, collecting responses from approximately 1,000 participants. The survey was designed to be fully comparable with the Australian survey developed in the previous year, while adapting non-mobility service attributes to the Japanese consumption and institutional context. Both surveys examined

user preferences for MaaS bundles combining mobility services (public transport, car-sharing, micromobility, and ride-hailing discounts) with non-mobility services such as entertainment, delivery, and reward schemes. This parallel design enabled robust international comparison of behavioural responses and willingness-to-pay across two distinct cultural and regulatory environments.

Using the combined Australian and Japanese datasets, a joint econometric analysis was undertaken to identify commonalities and differences in MaaS adoption drivers. The analysis focused on the role of pricing structures (pay-as-you-go versus subscription models), cross-subsidisation between mobility and non-mobility services, and context-specific factors such as commuting arrangements, car ownership constraints, and lifestyle consumption patterns. The results show that while flexible pay-as-you-go models are preferred in both countries, the relative valuation of mobility and non-mobility services differs substantially across contexts, highlighting the importance of context-sensitive bundle design for scaling MaaS.

The main findings from this comparative analysis were synthesised into a joint research paper and presented at the Transport Demand Management Conference held in Sydney in early December 2025. The presentation generated strong interest and constructive feedback from an international audience of researchers and practitioners. Building on this feedback, the research team is currently developing a full journal manuscript based on the joint Australia–Japan analysis, with the intention to submit it to a leading international journal for peer review and publication.

#### International/National Conference

- Ho C.Q, Militão A. M., Sasaki Y, Sato H., Yamamoto T. (2025) Scaling Mobility as a Service through Multiservice Platforms: Evidence from Australia and Japan, 12th International Symposium on Travel Demand Management, Sydney, Australia, 9 – 11 December 2025.